

**ALLEY PAVEMENT PROFILE**  
SCALE: 1:250 HOR  
1:10 VER

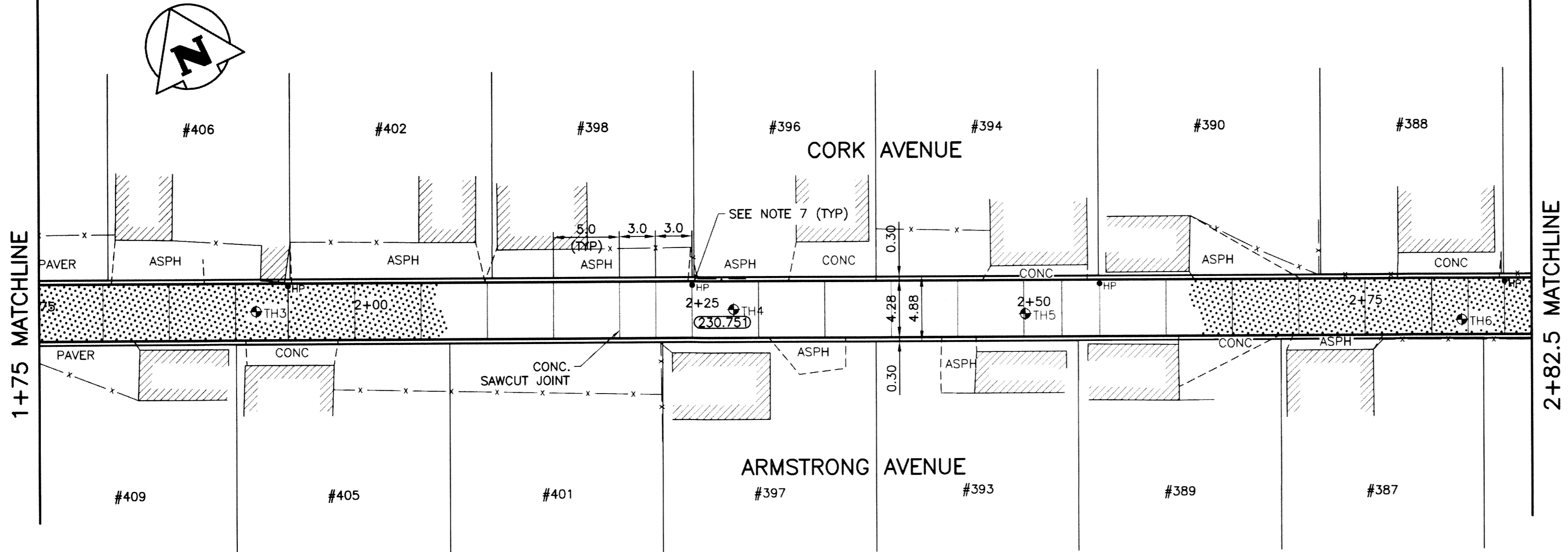

**ALLEY PAVEMENT PLAN**  
SCALE: 1:250 HOR

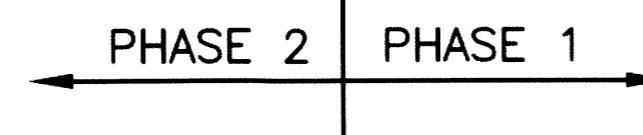
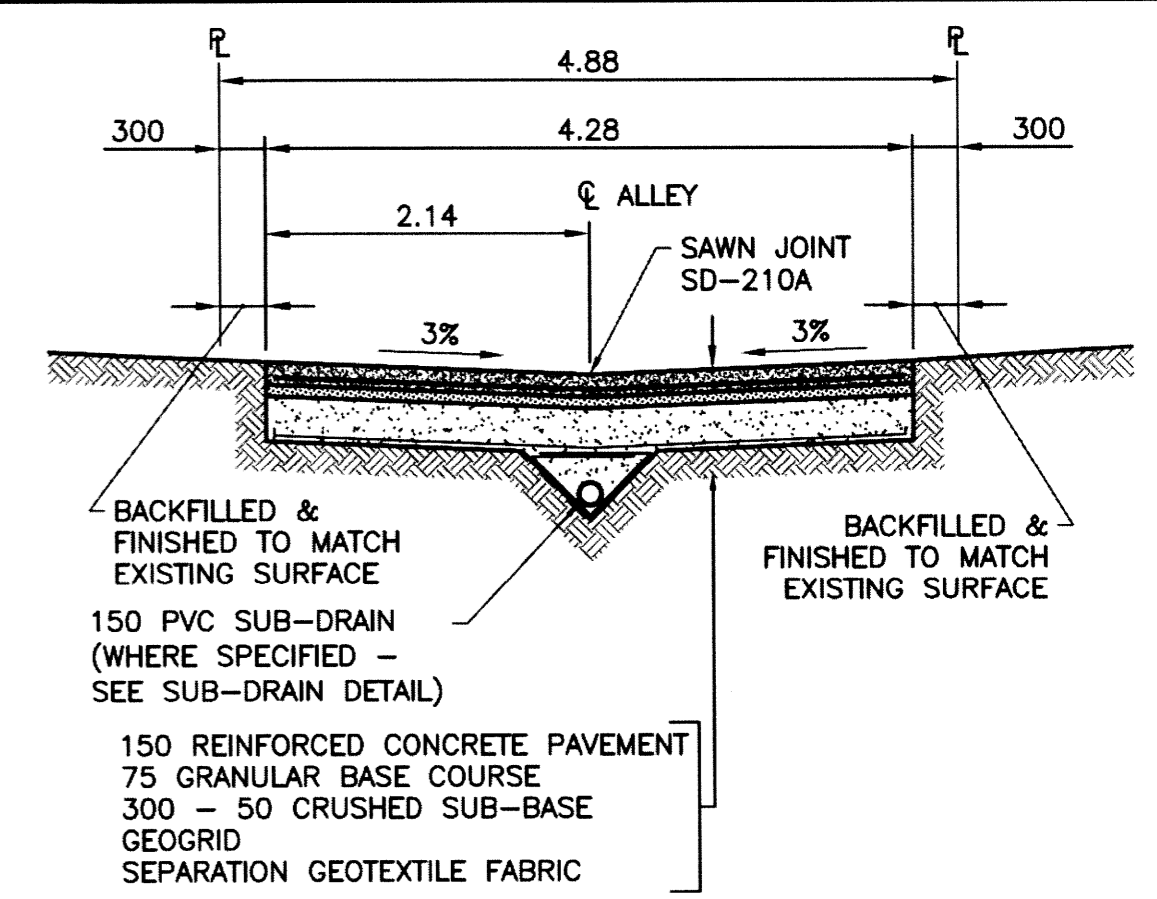

**TYPICAL CROSS SECTION**  
SCALE: 1:50

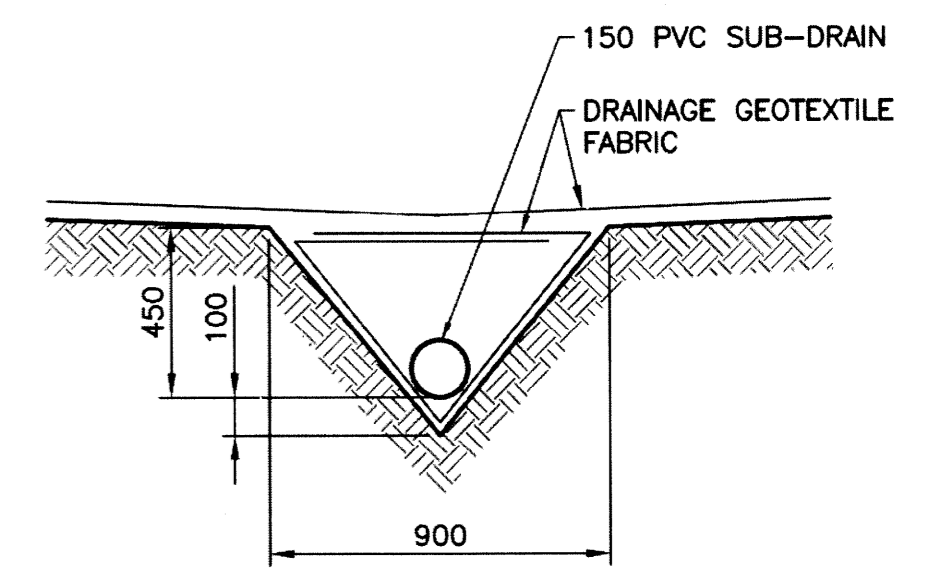

**SUB-DRAIN DETAIL**  
SCALE: 1:20

- NOTES**
1. STATION CHAINAGE IS BASED ON CENTERLINE OF ALLEY RIGHT OF WAY.
  2. ADJUST MH AND CB RIMS TO NEW GRADES.
  3. PLUG SUB-DRAINS AT TERMINAL ENDS.
  4. REGRADE EXISTING PRIVATE SIDEWALKS AS REQUIRED.
  5. INSTALLATION OF LIP CURBS AND THEIR EXTENTS TO BE DETERMINED BY THE CONTRACT ADMINISTRATOR.
  6. LIGHT STANDARDS, HYDRO POLES AND ANCHORS MAY REQUIRE TEMPORARY SUPPORT/REMOVAL OR REPLACEMENT AT THE CONTRACTOR'S EXPENSE.
  7. ISOLATE ALL POLES, BASES AND PILES WITHIN ALLEY RIGHT OF WAY (SD-228C).
  8. AVOID DAMAGE TO EXISTING TREES WITHIN THE LIMITS OF CONSTRUCTION.
  9. CITY OF WINNIPEG SURVEY MONUMENTS EXIST ON THIS SITE. CONTRACTOR TO CONTACT THE CITY OF WINNIPEG GEOMATICS BRANCH 5 WORKING DAYS IN ADVANCE OF CONSTRUCTION TO COORDINATE MONUMENT PROTECTION SERVICES (204-918-1360).
  10. ALLEY TO BE CONSTRUCTED IN PHASES AS SHOWN.
  11. ALL EXCAVATIONS WITHIN 1.0m OF ANY NATURAL GAS MAIN MUST BE COMPLETED BY HAND OR HYDRO EXCAVATION.

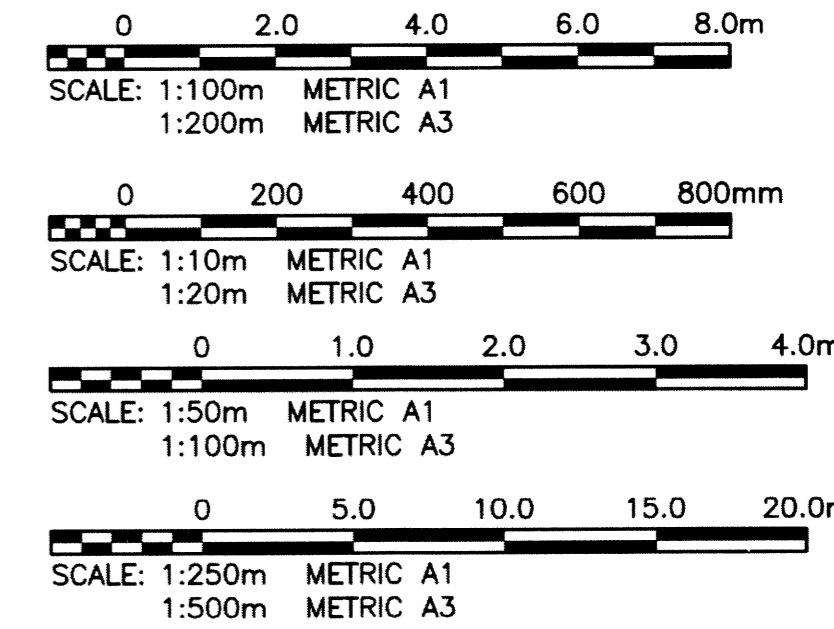

**METRIC**  
WHOLE NUMBERS INDICATE MILLIMETRES  
DECIMALIZED NUMBERS INDICATE METRES

**PROPERTY LIMITS DELINEATION**

**WARNING**  
NOTIFY THE GAS COMPANY OF THE PROPOSED LOCATION OF EXCAVATION. TAKE PRECAUTION TO AVOID DAMAGE TO GAS COMPANY INSTALLATIONS. SEE PROVINCIAL REGULATION 210/72 FOR DETAILS.

DELINEATION OF PROPERTY LIMITS AS SHOWN ON THIS DWG DOES NOT REPRESENT A "LEGAL SURVEY". KGS GROUP MAKES NO REPRESENTATION OR WARRANTY AS TO THE ACCURACY OF PROPERTY LIMITS DELINEATED ON THIS DWG, NOR ON THE DIMENSIONAL ACCURACY OF DWG FEATURES RELATIVE TO THOSE PROPERTY LIMITS.

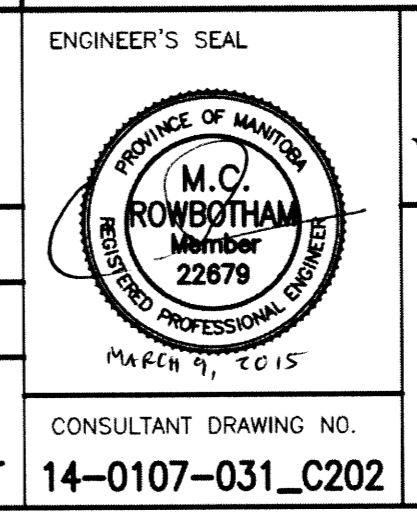
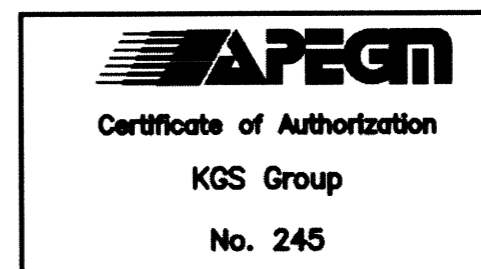

**THE CITY OF WINNIPEG**  
PUBLIC WORKS DEPARTMENT  
TRANSPORTATION ENGINEERING DIVISION

PROJECT TITLE  
**2015 ALLEY RENEWAL PROGRAM**  
CONTRACT 2  
**CORK AVE/ARMSTRONG AVE**  
S/LY DR TO SALTER ST  
STA 1+75 TO 2+82.5

SHEET OF  
**02** OF **15**

COMPUTER FILE NAME  
**14-0107-031\_Contract 2**

CITY DRAWING NUMBER  
**C202**

ENGINEER'S SEAL  
CONSULTANT DRAWING NO.  
**14-0107-031\_C202**

**LOCATION APPROVED UNDERGROUND STRUCTURES**

SUPV. U/G STRUCTURES COMMITTEE DATE

**NOTE:**  
LOCATION OF UNDERGROUND STRUCTURES AS SHOWN ARE BASED ON THE BEST INFORMATION AVAILABLE BUT NO GUARANTEE IS GIVEN THAT ALL EXISTING UTILITIES ARE SHOWN OR THAT THE GIVEN LOCATIONS ARE EXACT. CONFIRMATION OF EXISTENCE AND EXACT LOCATION OF ALL SERVICES MUST BE OBTAINED FROM THE INDIVIDUAL UTILITIES BEFORE PROCEEDING WITH CONSTRUCTION.

DESIGNED BY	GES	CHECKED BY	RBO
DRAWN BY	GES	APPROVED BY	CR
HOR. SCALE:	1:250	RELEASED FOR CONSTRUCTION:	
VERTICAL:	1:50	DATE	2015/02/05
NO. REVISIONS		DATE	

P:\Projects\2014\14-0107-031\_Contract 2.dwg - Tab: C202 Plotted By: gloewen 03/09/2015 [Mon 9:18am]  
 PLOT 1:1 A-1